

OT306 Conventional Heat Detector



Product Overview

OT306 Conventional Heat (Thermal) Detector is designed to meet the stringent performance requirements of industrial and municipal fire detection/alarm systems. With a precise NTC resistor which can sense the environment temperature. Its hardware filter can verify the true fire and reduce false alarm.

Characteristics

- Transnormal thin design for thickness , just 41mm (with base).
- Adopt SMT technology, firmly, high secure and antijamming.
- Special methods for dampproof , antiseptis and mildew proof.
- Flame retardant thermoplastic
- Easy plug-in of the head to base
- SEMS screws for easy wiring
- 2-wire without polarity
- Comply with Standard: GB4716-2005

Specifications

Operating Voltage: DC24V (20~28V)

Standby current: ≤ 0.25 mA

Alarm current: ≤ 22 mA (DC24V with 510 Ω resistor in series)

Operating environment: Temperature: -10° C~50° C Related Humidity: $\leq 95\%$ (40 ± 2 ° C)

Dimensions: Diameter 100 mm Height 41 mm

Weight: 65g

Configuration and Installation Guide

1. The Model of OT306 base is ODZ3007. Model 86H50 wall mounting enclosure or other

enclosure with 40~85mm mounting hole space should be used.

2. The side of detector bottom and the side of base has one convex edge each. There is one slot on the base. When mounting, make the convex edge pointing to the slot in the base, and then place the detector into the slot. Finally turn clockwise until the convex edge of the unit is flush with the convex edge of base.

Wiring

1 and 2 terminals are connected to the corresponding signal input terminals (without polarity) of fire alarm control panel or interface modules respectively. One EOL (End of Line) resistor should be connected in series between 1 and 3 terminals of the detector at the end of line. The specs of the resistor should refer to the requirement of control panel or interface module.

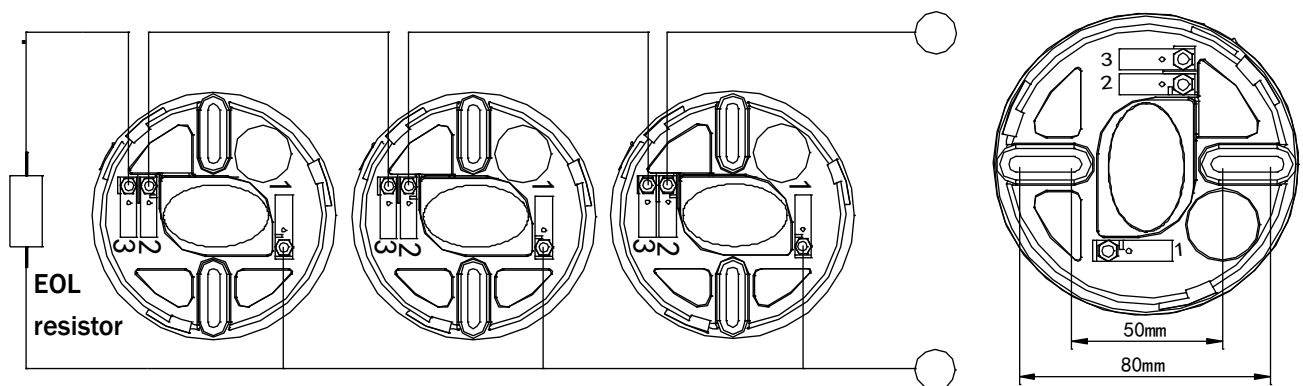

Notice

1. After installing, the detector has to be locked into the slots of base, and its convex edge should be flush with the convex edge of base. Otherwise, it will be reinstalled.
2. After installed onto the base, wire pipe on the ceiling should be sealed with sealing paste or sealing glue to prevent accumulated water going into the unit.
3. When connecting, the wire should be with cooled terminals or tinned, and can't be wound randomly.

Orena Sales and Service

Shenzhen Orena Photonic Technology Co. Ltd

Orena Bldg, No.691# Longjing Road, Nanshan District, Shenzhen, 518055, P.R.China

Ph: 86.755.2678.7499 86.755.8623.3886 Fx: 86.755.2678.7499

E-mail: oem@orena.com.cn sales@orena.com.cn www.orena.com.cn

Orena Group (Hong Kong) Limited

Rm 1105, Lippo Centre Tower 1, 89 Queensway, Admiralty, Hong Kong

Tel: 852.2537.7886 Fax: 852.2537.7780 www.orenahk.com